



BEFOND

瑞豐光電



## 1. Description 产品介绍

### 1.1 General Description 产品描述

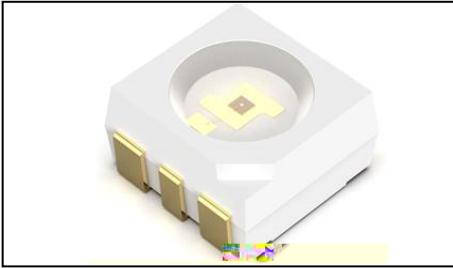

The red source color devices are made with AlGaInP on Substrate Light Emitting Diode .Product Package:3.5mmX3.5mmX1.9mm.

该红光 LED 由 AlGaInP 四种元素芯片激发而成，产品尺寸：3.5mmX3.5mmX1.9mm.。

### 1.2 Features 产品特征

PLCC6 Package. PLCC6封装

Extremely wide viewing angle. 发光角度大

Suitable for all SMT assembly and solder process. 适用于所有的SMT组装和焊接工艺

Available on tape and reel. 适用于载带及卷轴

Moisture sensitivity level: Level 2. 防潮等级 Level2

Compliance with RoHS and REACH. 符合RoHS和REACH要求

Qualifications: The product qualification test plan is based on the guidelines of AEC-Q102 Stress Test Qualification for Automotive Grade Discrete Semiconductors 资格：产品资格测试计划基于 AEC-Q102 汽车级分立半导体应力测试资格准则

### 1.3 Application 产品应用

Automotive Lighting Interior and Exterior. 汽车内饰和外饰照明



## 1.4 Package Dimension 封装尺寸



### Notes 备注:

1. All dimensions units are millimeters.





REFOND

瑞豐光電





REFOND

瑞豐光電



BEFOND

瑞豐光電



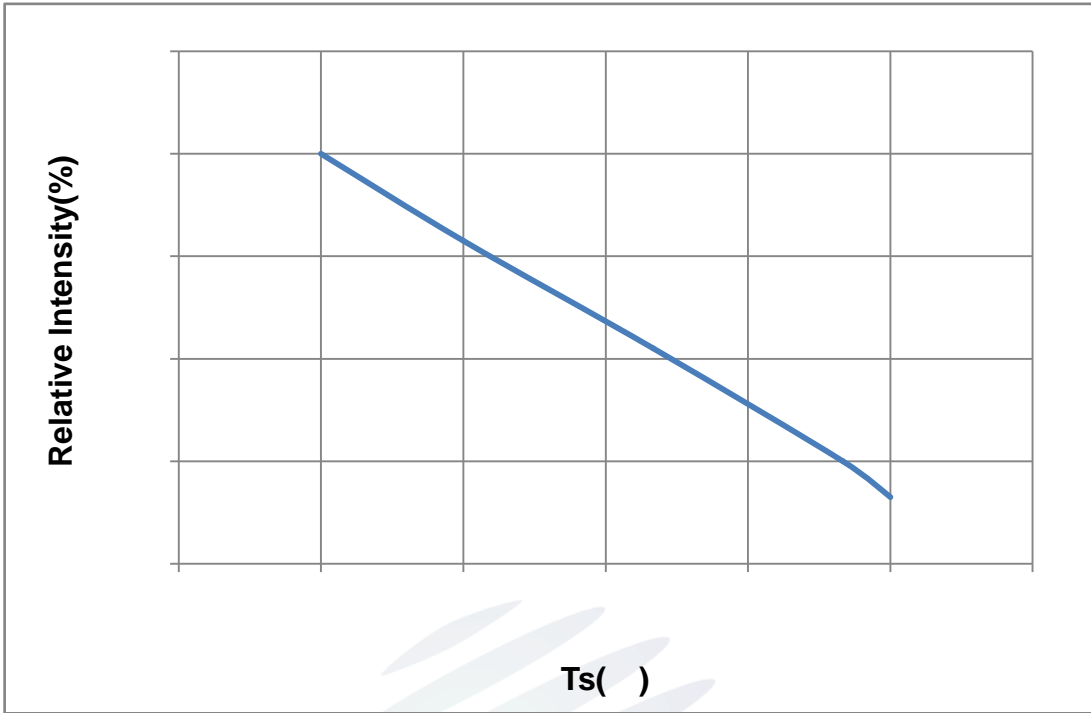

Fig. 1-9 Solder Temperature Vs Relative Intensity 管脚温度与相对光强特性曲线

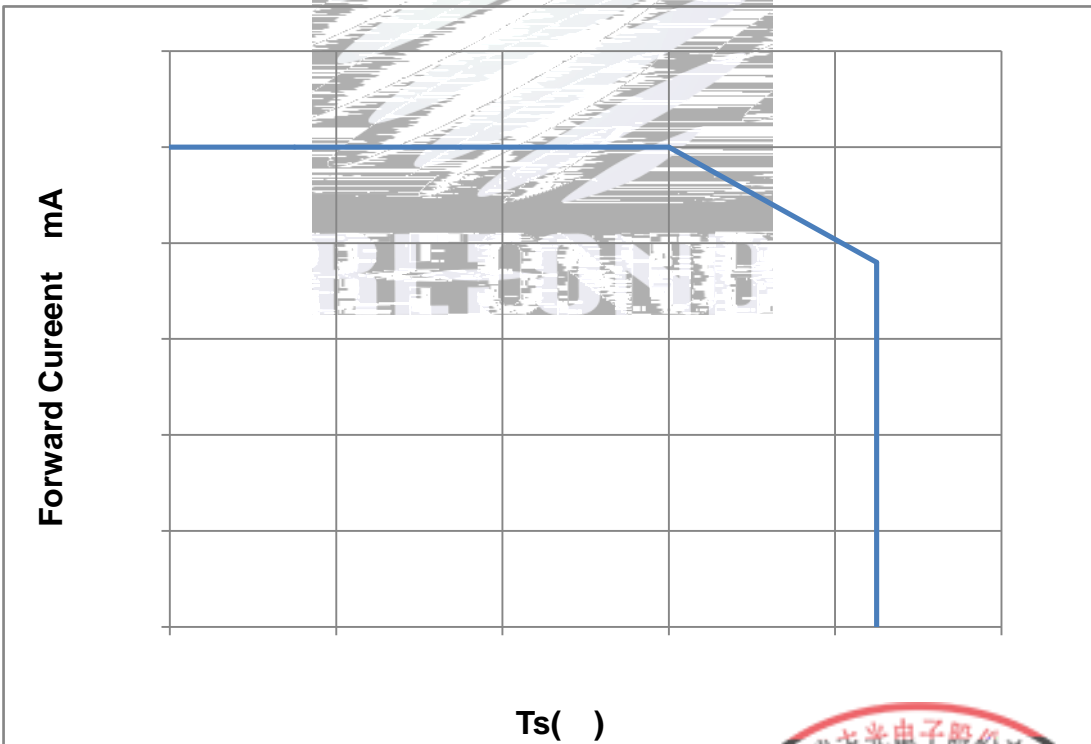

Fig. 1-10 Solder Temperature Vs Forward Current 管脚温度与正向电流特性曲线

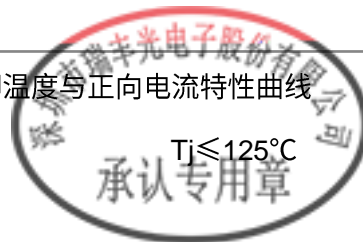



Fig. 1-11 Forward Voltage Vs Solder Temperature 电压与管脚温度特性曲线



Fig. 1-12 Radiation diagram 辐射特性曲线



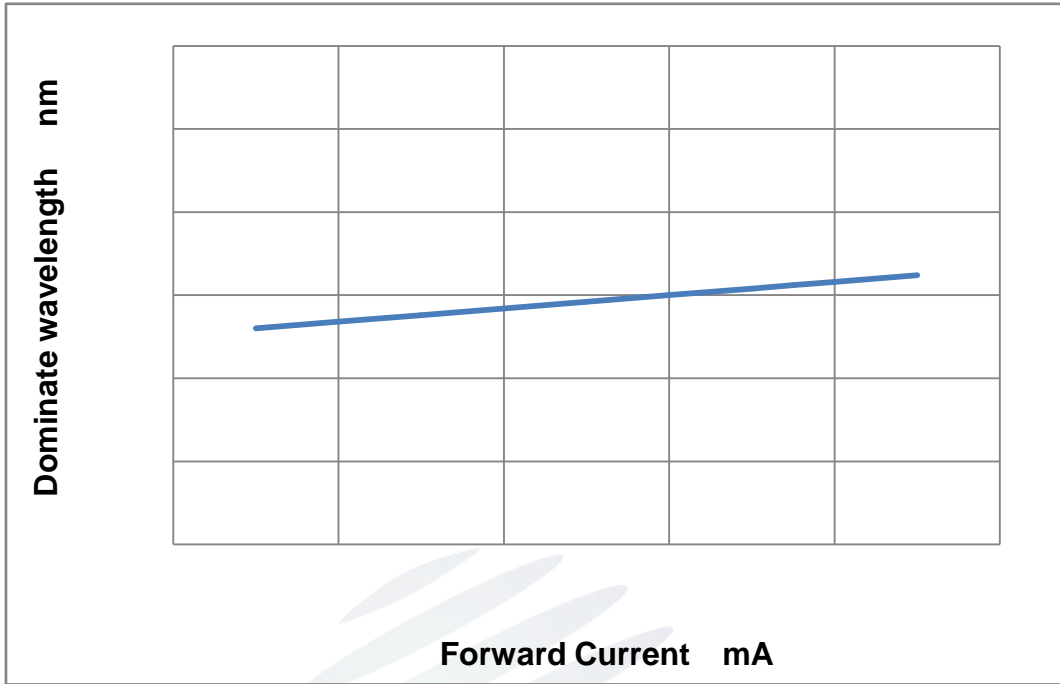

Fig. 1-13 Forward current vs. Dominate wavelength正向电流与主波长特性曲线 (Ts=25°C)

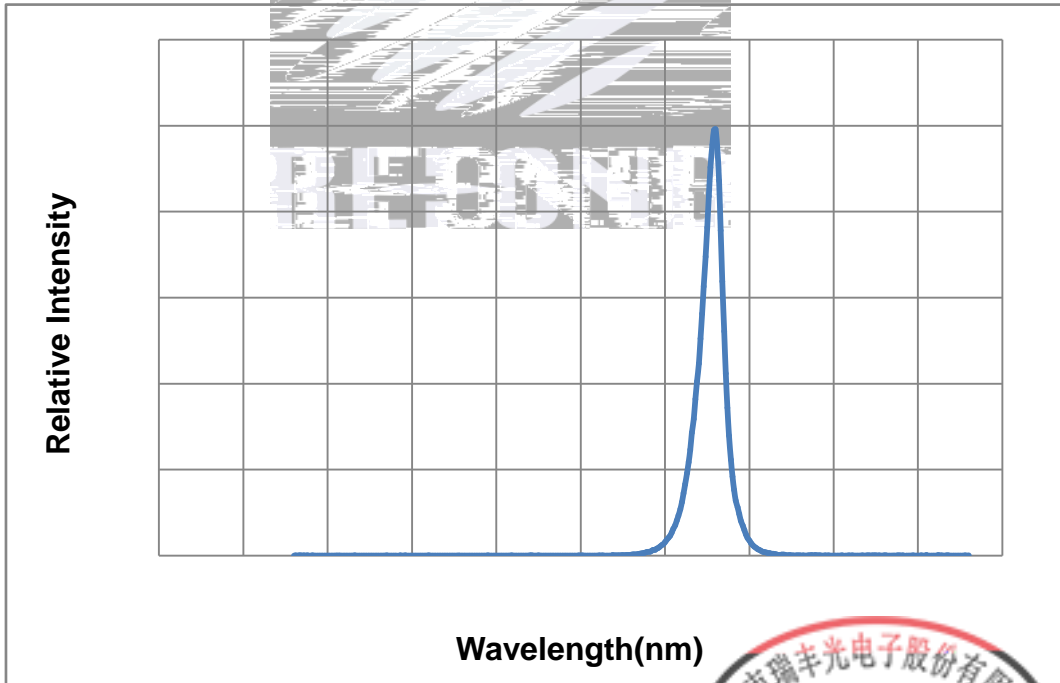

Fig. 1-14 Spectrum Distribution光谱分布特性曲线



## 2. Packaging 产品包装

### 2.1 Packaging Specification 包装规格

Package: 4000pcs/reel. 包装每卷 。

#### 2.1.1 Carrier Tape Dimension 载带尺寸

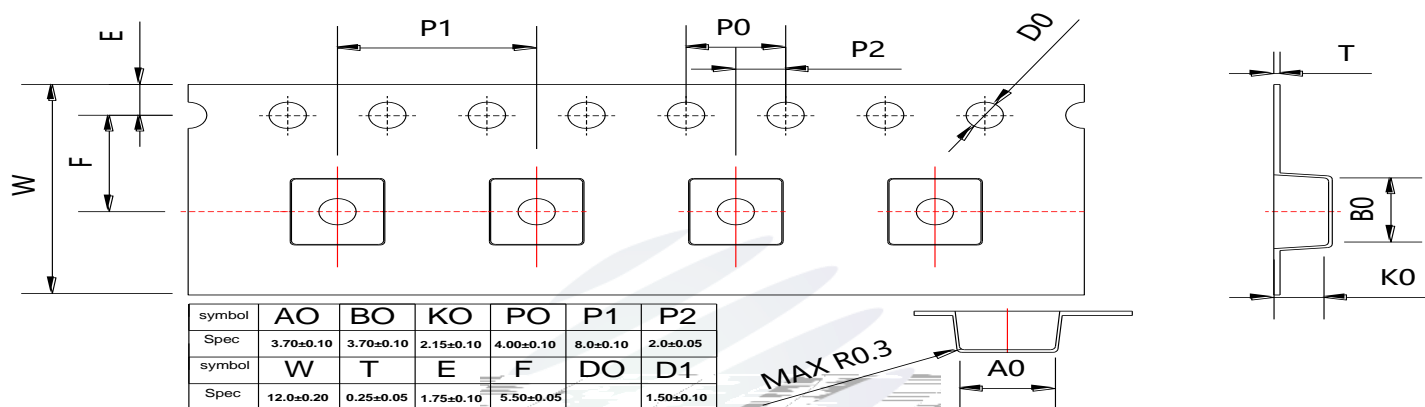

Fig.2-1 Carrier Tape Dimension 载带尺寸

#### 2.1.2 Reel Dimension 卷盘尺寸

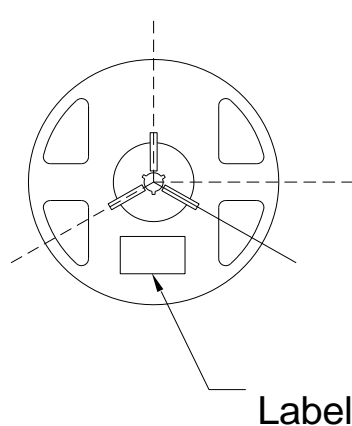

Fig.2-2 Reel Dimension 卷盘尺寸

Table 2-1 Reel Dimension 卷盘尺寸

|   |            |
|---|------------|
| A | 12±0.1mm   |
| B | 330±1mm    |
| C | 100±1mm    |
| D | 13.0±0.5mm |

#### Notes 备注:

The tolerances unless mentioned ±0.1mm. Unit : mm. 注: 未注公差为±0.1毫米, 尺寸单位: 毫米.



### 2.1.3 Label Form Specification 标签规格

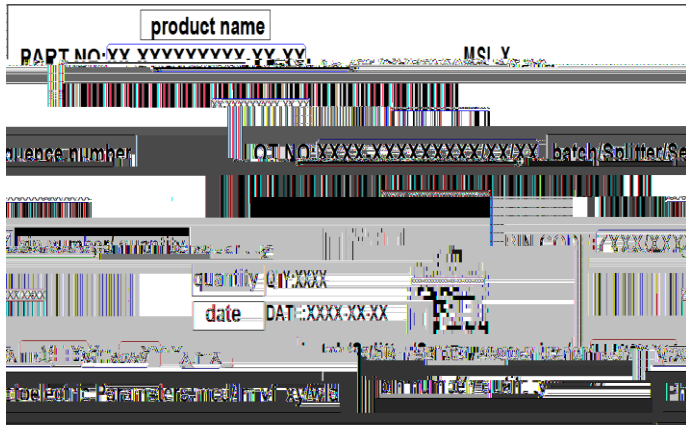

Fig. 2-3 Label 标签

Table 2-2 Specification 规格

|                |                      |
|----------------|----------------------|
| PART NO.       | Part Number 品名       |
| SPEC NO.       | Spec Number 规格       |
| LOT NO.        | Lot Number 批次号       |
| BIN CODE       | Bin Code 参数代码        |
|                | Luminous flux 光通量    |
| XY             | Chromaticity Bin 色区  |
| V <sub>F</sub> | Forward Voltage 正向电压 |
| WLD            | Wavelength 波长代码      |
| QTY            | Packing Quantity 数量  |
| DATE           | Made Date 生产日期       |

### 2.2 Moisture Resistant Packing 防潮包装

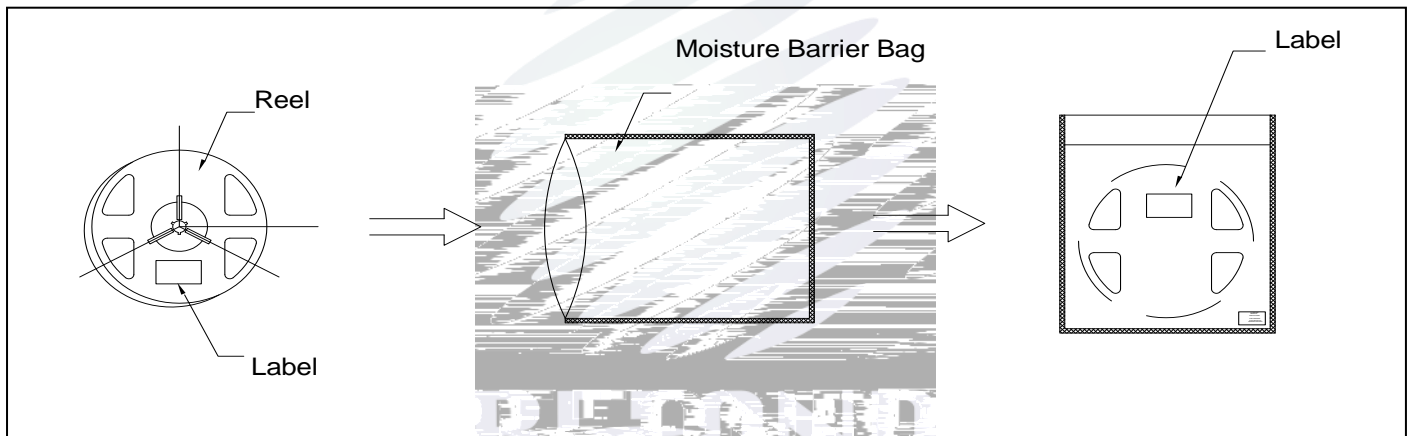

Fig.2-4 Moisture Resistant Packing

### 2.3 Cardboard Box 包装纸箱

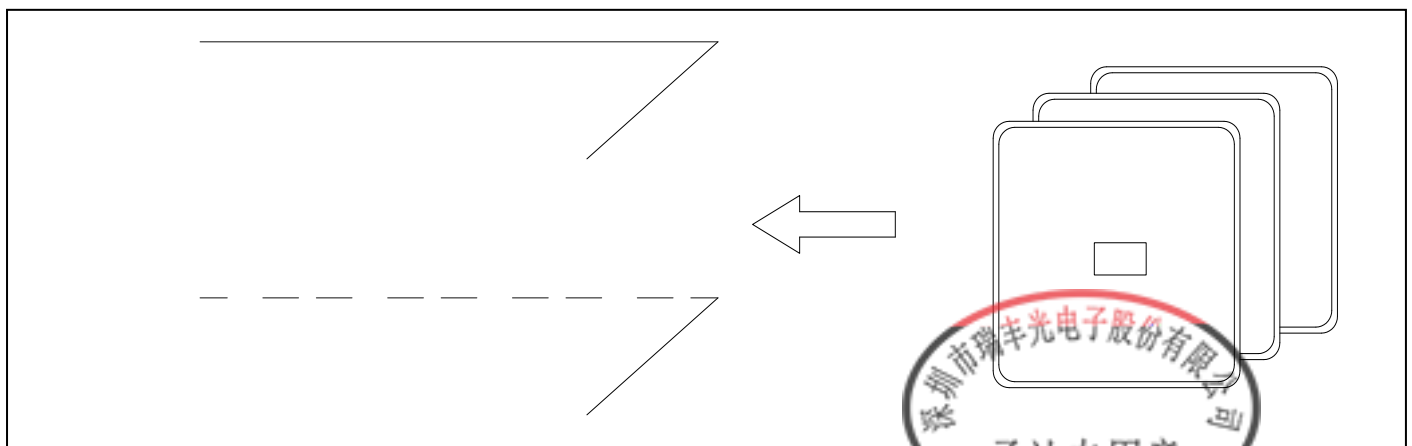

Fig.2- Cardboard Box



REFOND

瑞豐光電

## 2.5 Criteria For Judging Damage 失效判定标准

Table 2-4 Criteria For Judging Damage 失效判定标准

| Test Items<br>项目        | Symbol<br>符号 | Test Condition<br>测试条件 | Criteria For Judgement<br>判定标准 |             |
|-------------------------|--------------|------------------------|--------------------------------|-------------|
|                         |              |                        | Min. 最小                        | Max. 最大     |
| Forward Voltage<br>正向电压 | $V_F$        | $I_F=150\text{mA}$     | -                              | U.S.L*)x1.1 |
| Reverse Current<br>反向电流 | $I_R$        | $V_R = 5\text{V}$      | -                              | U.S.L*)x2.0 |
| Luminous Flux<br>光通量    |              | $I_F=150\text{mA}$     | L.S.L*)x0.7                    | -           |

### Notes 备注:

- 1.U.S.L: Upper standard level 规格上限 L.S.L: Lower standard level 规格下限
- 2.The above reliability tests is based on the verification of a single/strip LED of Refond's existing experimental platform,the reliability experiment was taken under good heat dissipation conditions. when customers applies the LED to the series and parallel circuit, should take consideration of all the factors such as the current, voltage distribution, heat dissipation and others.以上可靠性测试是基于瑞丰现有实验平台单颗/条 LED 在良好散热条件验证下的结果。客户端将 LED 应用于串、并联线路时, 需自行评估电流、电压分配、散热等问题。
- 3.The technical information shown in the data sheets is limited to the typical characteristics and circuit examples of the referenced products. It does not constitute the warranting of industrial property nor the granting of any license. 以上技术数据仅为产品的典型值, 只作为参考, 不作为任何应用条件及应用方式的保证。



### 3. SMT Reflow Soldering Instructions SMT 回流焊说明

#### 3.1 SMT Reflow Soldering Instructions SMT 回流焊说明

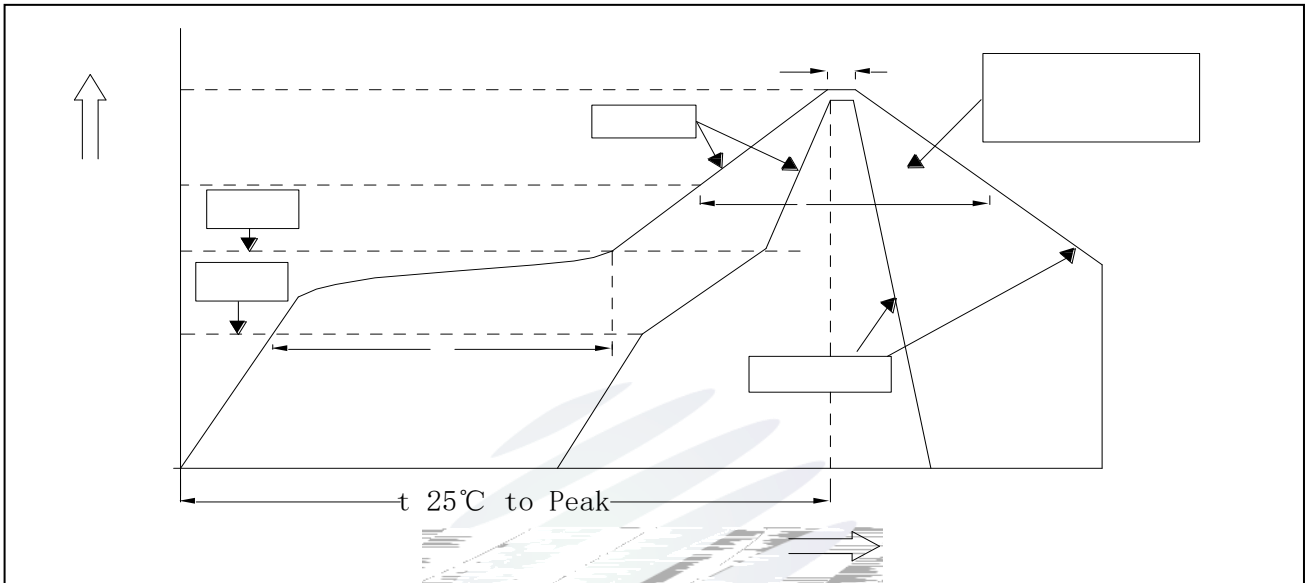

Fig.3-1 SMT Reflow Soldering Instructions SMT 回流焊说明

Table 3-1 Reflow parameters

|   |                      |
|---|----------------------|
| Average temperature rise speed 平均升温速度 (T <sub>smáx</sub> 至 T <sub>P</sub> )                                   | 最高3 °C/秒 Max 3 °C/ s |
| Preheating: minimum temperature 预热: 最低温度 (T <sub>smín</sub> )   | 150 °C               |
| Preheating: Max temperature 预热: 最高温度 (T <sub>smáx</sub> )   | 200 °C               |
| Preheating: Time 预热: 时间 (T <sub>smín</sub> 至 T <sub>smáx</sub> )  | 60 - 120秒 60s-120s   |
| Time limited to maintain high temperature: the temperature 限时维持高温: 温度 (T <sub>L</sub> )                       | 217 °C               |
| Time limited to maintain high temperature: The Time (t <sub>L</sub> )   | 最多60秒 Max 60s        |
| Peak /Classification of temperature: 峰值 / 分类温度 (T <sub>P</sub> )  | 260 °C               |
| Time limit classification of peak temperature time 限时峰值分类温度: 时间 (t <sub>p</sub> )                             | 最多10秒 Max 10s        |
| Hold time within 5°C with the actual peak temperature (T <sub>P</sub> ) 与实际峰值温度(T <sub>P</sub> )相差5°C 以内的保持时间 | 最多30秒 Max 30s        |
| Cooling speed 降温速度  | 最高6 °C/秒 Max 6 °C/ s |
| Needed time from 25 °C to T <sub>p</sub> 25°C升至峰值温度所需时间   | 最多8分钟 Max 8 minutes  |



Notes 备注:

(1)Reflow soldering should not be done more than twice. If more than 24 hours between the two solderings , LED will be damaged. 回流焊次数不可以超过两次，两次回流焊的时间间隔如果超过24小时，LED可能由于吸湿而损坏。

(2)When soldering , do not put stress on the LEDs during heating.当焊接时，不要在材料受热时用力压胶体表面。

3.1.1 Soldering Iron 烙铁焊接

(1) When do soldering by hand, keep the temperature of iron below less 300 less than 3 seconds 当手工焊接时,烙铁的温度必须小于300°C，时间不可超过3秒。

(2) Soldering by hand should be done only one time.手工焊接只可焊接一次。

3.1.2 Repairing 修复

Repairing should not be done after the LEDs have been soldered. When repairing is unavoidable,a double-head soldering iron should be used (as below figure). It should be confirmed in advance whether the characteristics of LEDs will or not be damaged by repairing.

LED回流焊后不应该修复，当必须修复时，必须使用双头烙铁，而且事先应确认此种方式会不会损坏LED本身的特性。

3.1.3 Cautions 注意事项

The encapsulated material of the LEDs is silicone. Therefore the LEDs have a soft surface on the top of package. The pressure to the top surface will be impacted on the reliability of the LEDs. Precautions should be taken to avoid the strong pressure on the encapsulated part. So when use the picking up nozzle, the pressure on the silicone resin should be proper. LED封装胶为硅胶，表面较软，用力按压胶体表面会影响LED可靠性，因此应有预防措施避免在按压器件，当使用吸嘴时，胶体表面的压力应是恰当的。

(2) Components should not be mounted on warped (non coplanar) portion of PCB. After soldering, do not warp the circuit board.LED 灯珠不要焊接在弯曲的 PCB 板上，焊接之后，也不要弯折线路板。

(3) Do not apply mechanical force or excess vibration during the cooling process to normal temperature after soldering. Do not rapidly cool device after soldering.回流焊之后冷却过程中，不要对材料施加外力，也不要震动，回流焊后，不要采用激剧冷却的方式。

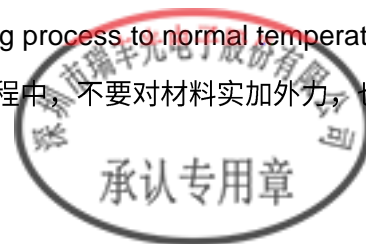





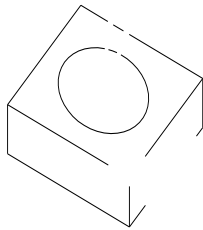

Fig 4-1 Handling Precautions 产品使用注意事项

(5) In designing a circuit, the current through each LED can not exceed the absolute maximum rating specified for each LED. In the mean while, resistors for protection should be applied, other wise slight voltage shift will cause big current change, burn out may happen. The driving circuit must be designed to allow forward voltage only when it is ON or OFF. If the reverse voltage is applied to LED, migration can be generated resulting in LED damage. 设计电路时，通过 LED 的电流不能超过规定的最大值，同时，还需使用保护电阻，否则，微小的电压变化将会引起较大电流变化，可能导致产品损毁。电路设计必须保证只有在开启或者关闭的时候出现正向电压的变化，不要施加反压，否则会损坏 LED。

(6) Thermal Design is paramount importance because heat generation may result in the Characteristics decline, such as brightness decreased, Color change and so on. Please consider the heat generation of the LEDs when making the system design. LED 正负温度变化对 LED 的性能影响较大，温度升高会降低 LED 发光效率，影响发光颜色，所以在设计时应充分考虑散热问题。

(7) Compared to standard encapsulants, silicone is generally softer, and the surface is more likely to attract dust, requiring special care during processing. In cases where a minimal level of dirt and dust particles cannot be guaranteed, a suitable cleaning solution must be applied to the surface after the soldering of components. Refond suggests using isopropyl alcohol for cleaning. In case other solvents are used, it must be assured that these solvents do not dissolve the package or resin. Ultrasonic cleaning is not recommended. Ultrasonic cleaning may cause damage to the LED. 与其他封装材料相比，硅胶通常较软，表面更易吸附灰尘，应用时应特别注意，当对产品洁净度要求较高时，回流焊以后需要采用恰当的清洗方式，我们推荐用异丙醇作清洗剂，如需要用到其他清洗剂，必须保证不会破坏封装体，超声清洗可能会对 LED 带来损害，不推荐这种清洗方式。



Table 4-1 Storage 儲存

| Conditions<br>种类 |                                    | Temperature<br>温度 | Humidity<br>湿度 | Time<br>时间  |
|------------------|------------------------------------|-------------------|----------------|---|
| Storage          | Before Opening Aluminum Bag<br>拆包前 | ≤30°C             | ≤75%           | Within 1 Year From Date<br>一年内                      |
|                  | After Opening Aluminum Bag<br>拆包后  | ≤30°C             | ≤60%           | Recommended for use<br>within 24 hours<br>建议24小时内使用 |
| Baking<br>烘烤     |                                    | 60±5°C            | -              | ≥24hours<br>大于24小时                                  |

(8) If the moisture absorbent material silica gel has faded away or the LEDs have exceeded the storage time, baking treatment should be performed after unpacking and based on the following condition 60 ± 5 for above 24 hours. 如果干燥剂或包装失效，或者产品不符合以上有效储存条件，需拆包后进行烘烤，烘烤条件：60±5°C，大于 24 小时。

If the package is flatulence or damaged, please notify the sales staff to assist. 如果包装胀气或者破损，请通知销售人员协助处理。

(9) Similar to most Solid state ir33(l)-4(arr5909;f)-6(f-12( )5(LE)-3(D)-4ast)5(u)-11es ensif co6havetoeria(R)tg to

| Date日期                | Revisor修订者    | Version版本 | Verifier审核        | Remarks备注 |
|-----------------------|---------------|-----------|-------------------|-----------|
| 2022/12/23            | 陆鲜<br>Lu Xian | E0        | 朱益明<br>Zhu Yiming | New issue |
| <del>2022/12/23</del> | 陆鲜<br>Lu Xian | E1        | 朱益明<br>Zhu Yiming | Update    |
|                       |               |           |                   |           |
|                       |               |           |                   |           |
|                       |               |           |                   |           |
|                       |               |           |                   |           |
|                       |               |           |                   |           |
|                       |               |           |                   |           |
|                       |               |           |                   |           |
|                       |               |           |                   |           |
|                       |               |           |                   |           |
|                       |               |           |                   |           |
|                       |               |           |                   |           |
|                       |               |           |                   |           |
|                       |               |           |                   |           |
|                       |               |           |                   |           |
|                       |               |           |                   |           |
|                       |               |           |                   |           |
|                       |               |           |                   |           |

