

SPECIFICATION



..... 3

..... 3

..... 3

..... 3

..... 4

..... 5

..... 7

..... 11

..... 11

..... 11

..... 11

..... 12

..... 12

..... 13

..... 13

..... 14

..... 15

..... 15

..... 17

..... 17

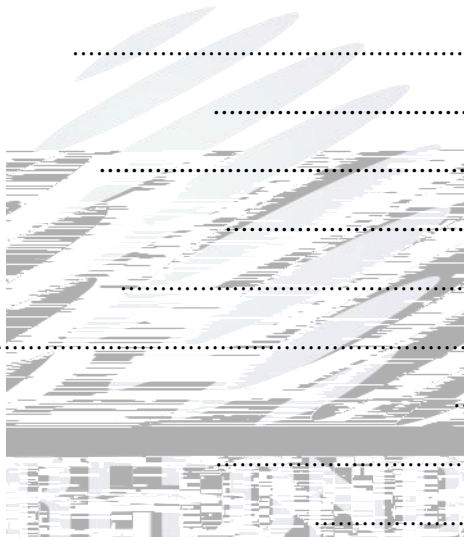

1. Description

1.1 General Description

1.2 Features

1.3 Application



1.4 Package Dimension

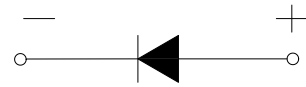
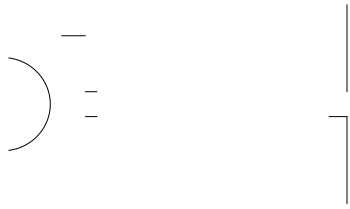

1.5 Product Parameters



| | | | |
|--|--|--|--|
| | | | |
| | | | |
| | | | |
| | | | |
| | | | |
| | | | |
| | | | |
| | | | |

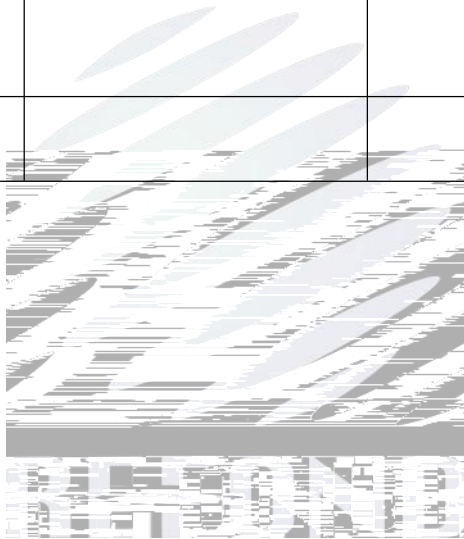

1.6 Typical Optical Characteristics Curves



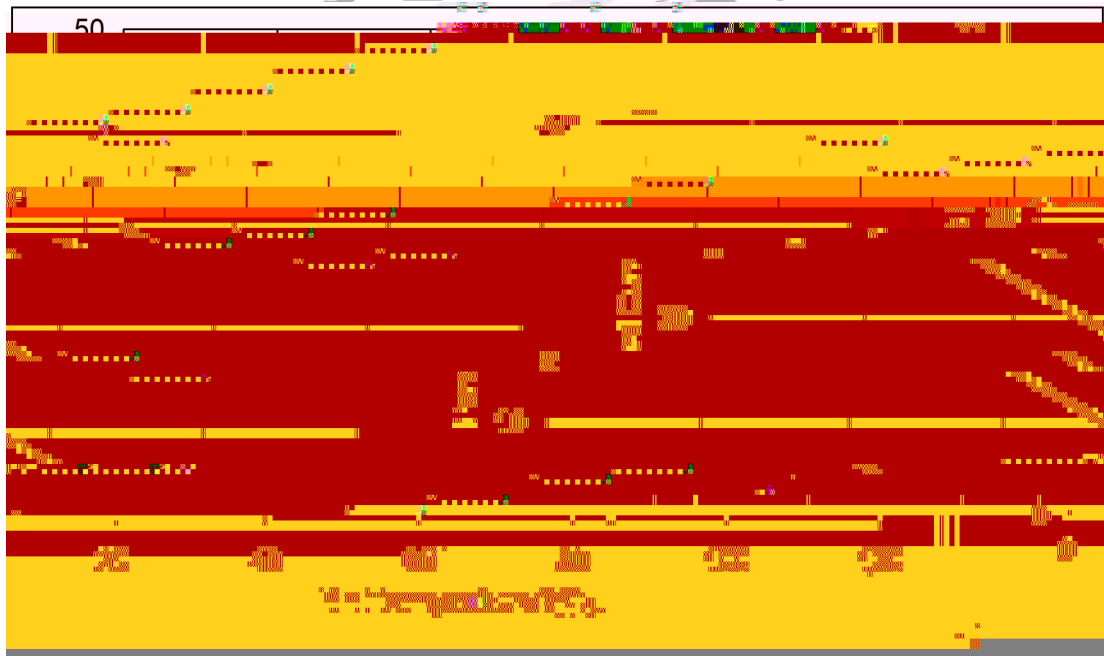



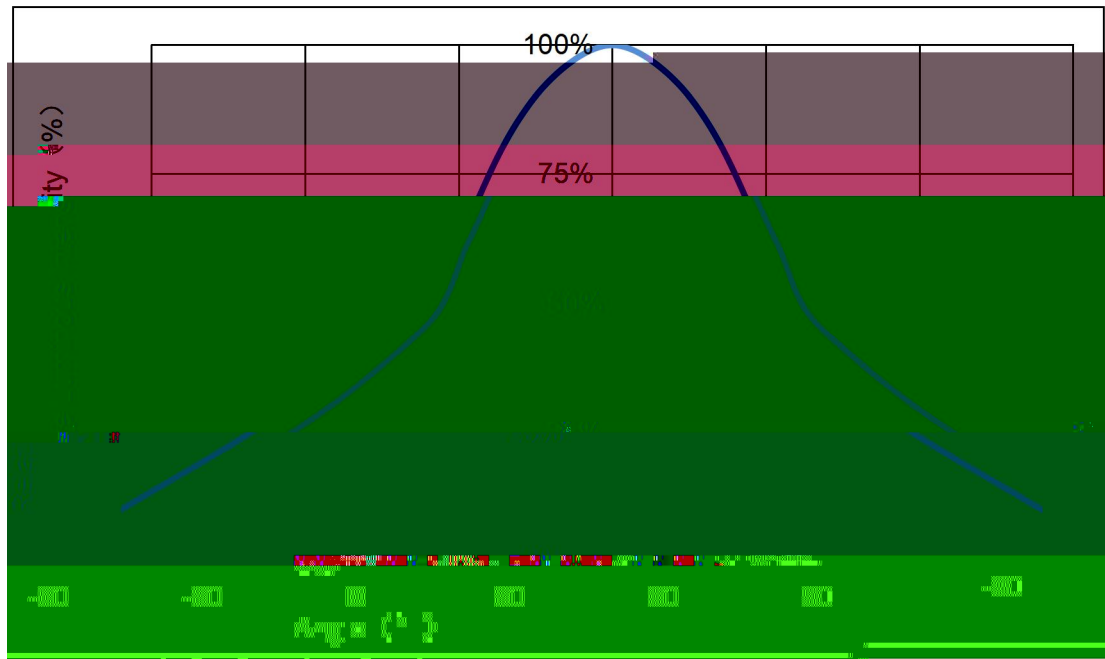

2. Packaging

2.1 Packaging Specification

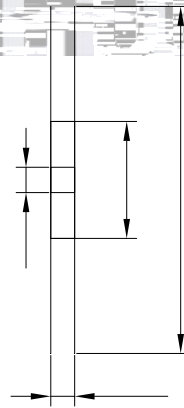
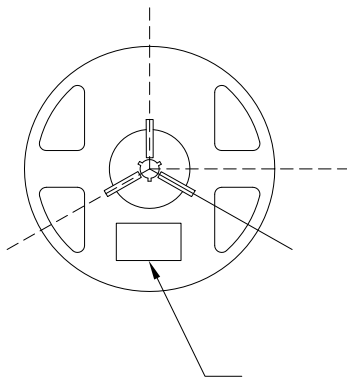
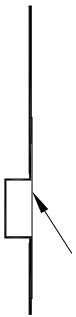

| | |
|--|--|
| | |
| | |
| | |
| | |



2.3 Cardboard Box

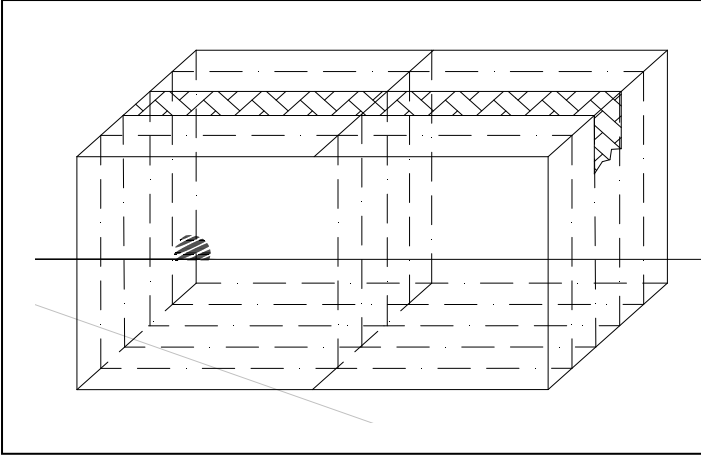

2.4 Reliability Test Items And Condition

| | | | | | |
|--|--|--|--|--|--|
| | | | | | |
| | | | | | |
| | | | | | |
| | | | | | |
| | | | | | |
| | | | | | |
| | | | | | |
| | | | | | |
| | | | | | |
| | | | | | |

2.5 Criteria For Judging Damage

| | | | | |
|--|--|--|--|--|
| | | | | |
| | | | | |
| | | | | |
| | | | | |



3. SMT Reflow Soldering Instructions SMT

3.1 SMT Reflow Soldering Instructions SMT

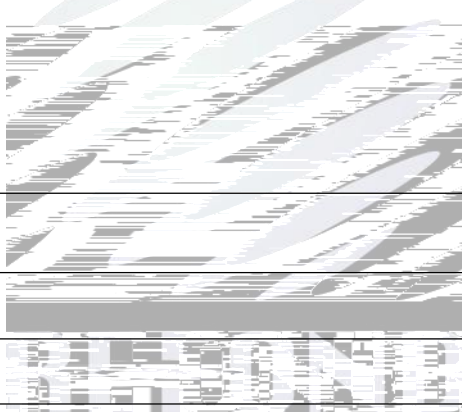
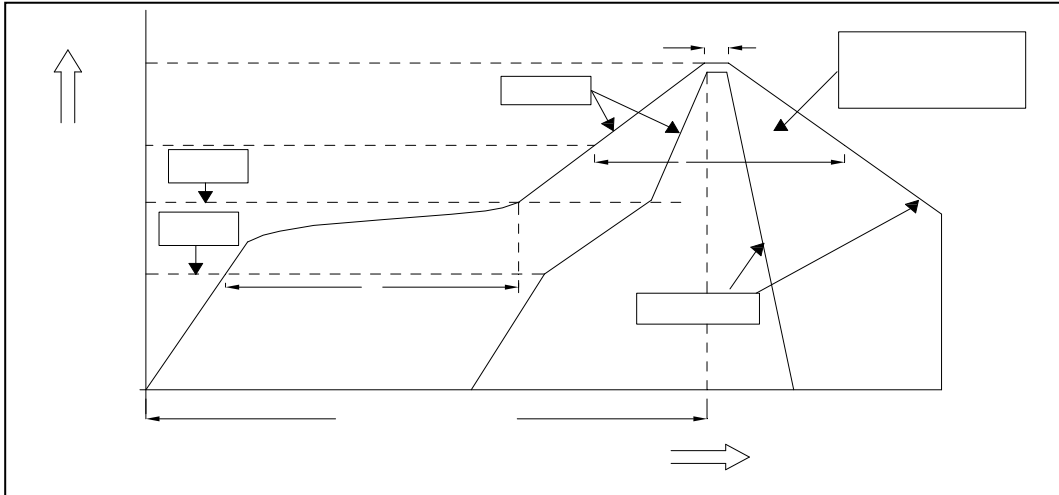

| | | |
|--|--|--|
| | | |
| | | |
| | | |
| | | |
| | | |
| | | |
| | | |
| | | |
| | | |
| | | |



4. Handling Precautions

4.1 Handling Precautions



Q @ n





| | | | | |
|--|--|--|--|--|
| | | | | |
| | | | | |
| | | | | |
| | | | | |
| | | | | |
| | | | | |
| | | | | |
| | | | | |
| | | | | |
| | | | | |
| | | | | |
| | | | | |
| | | | | |
| | | | | |
| | | | | |
| | | | | |
| | | | | |
| | | | | |
| | | | | |
| | | | | |
| | | | | |
| | | | | |
| | | | | |
| | | | | |

