

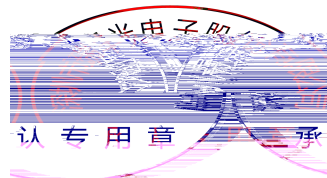

世通电子

REFUND 2017 REFORD 世通电子

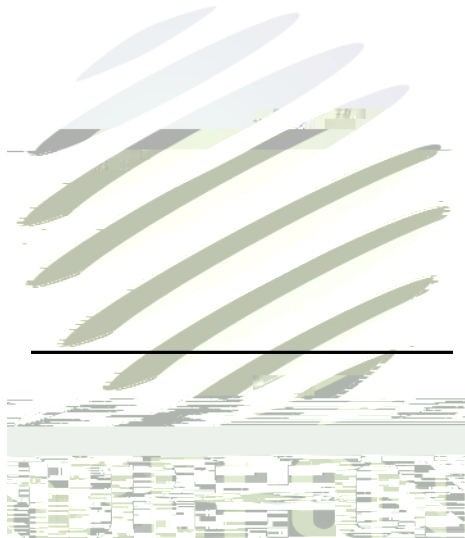



世通电子

REFUND 2017 REFORD 世通电子

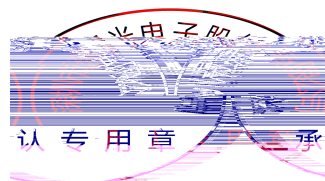
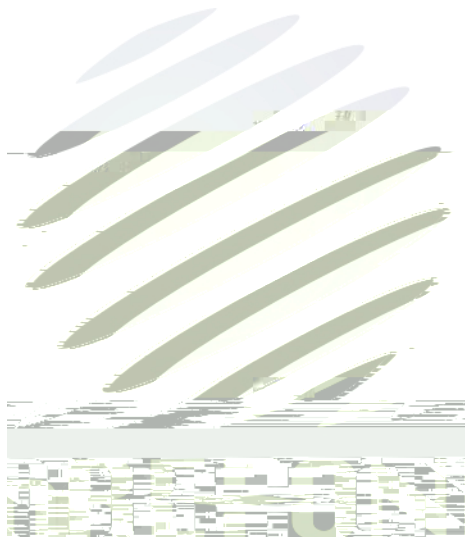



世通云商

REFOUND 2017 REFOUND 2017 世通云商

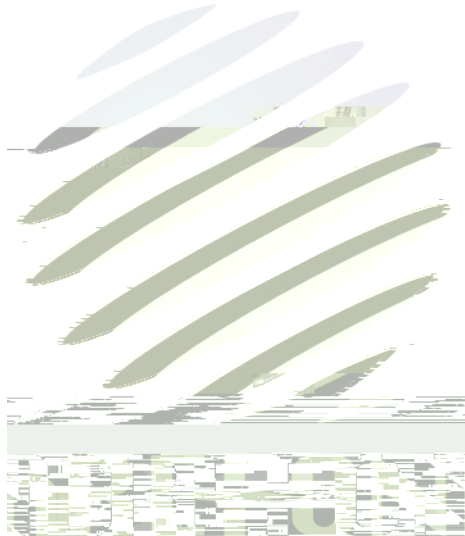
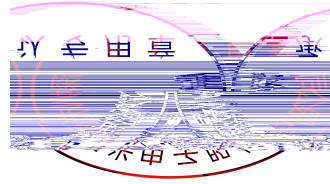

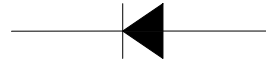
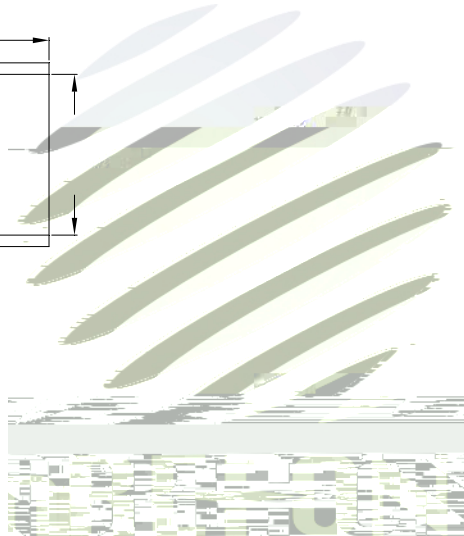
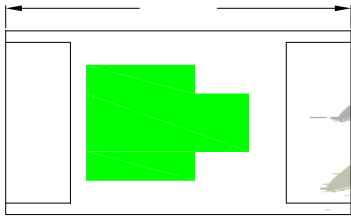
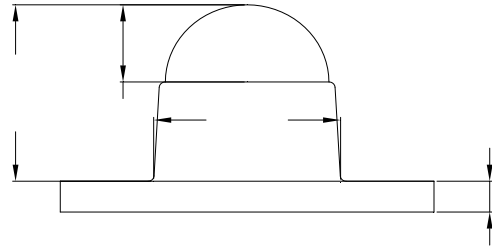
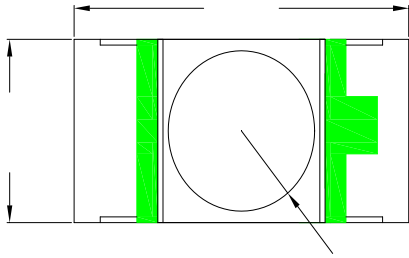

±



							μ

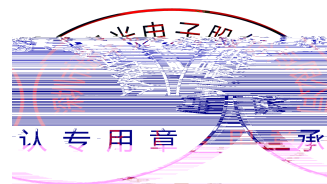

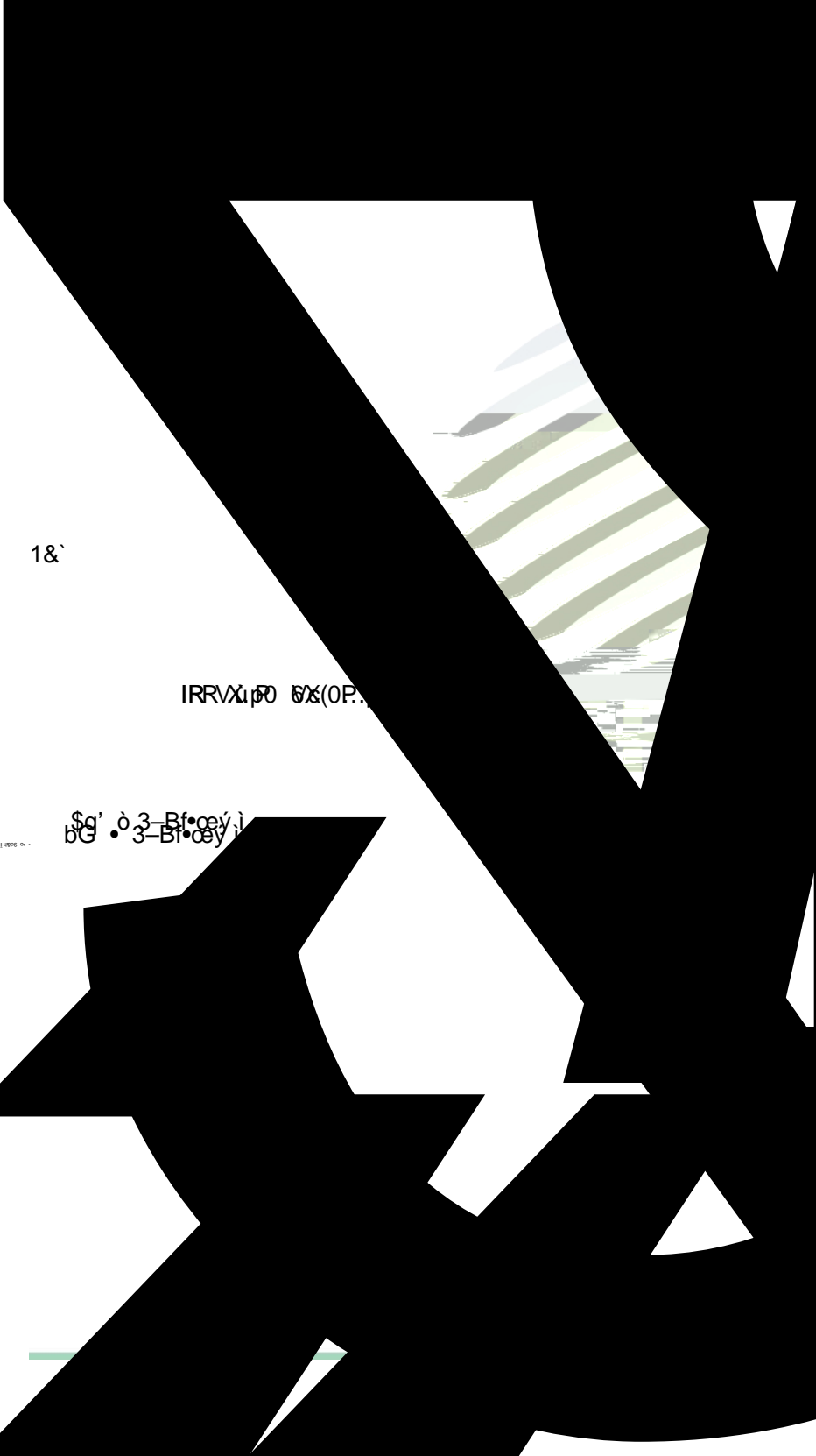

1&

IRRVA, pD 6% (OP.

Sd' 0 3-Bf. ceý i
bG • 3-Bf. ceý i

Y-01 1998 0 -

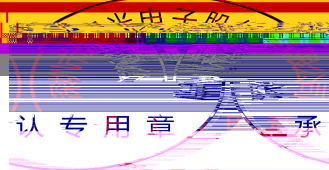
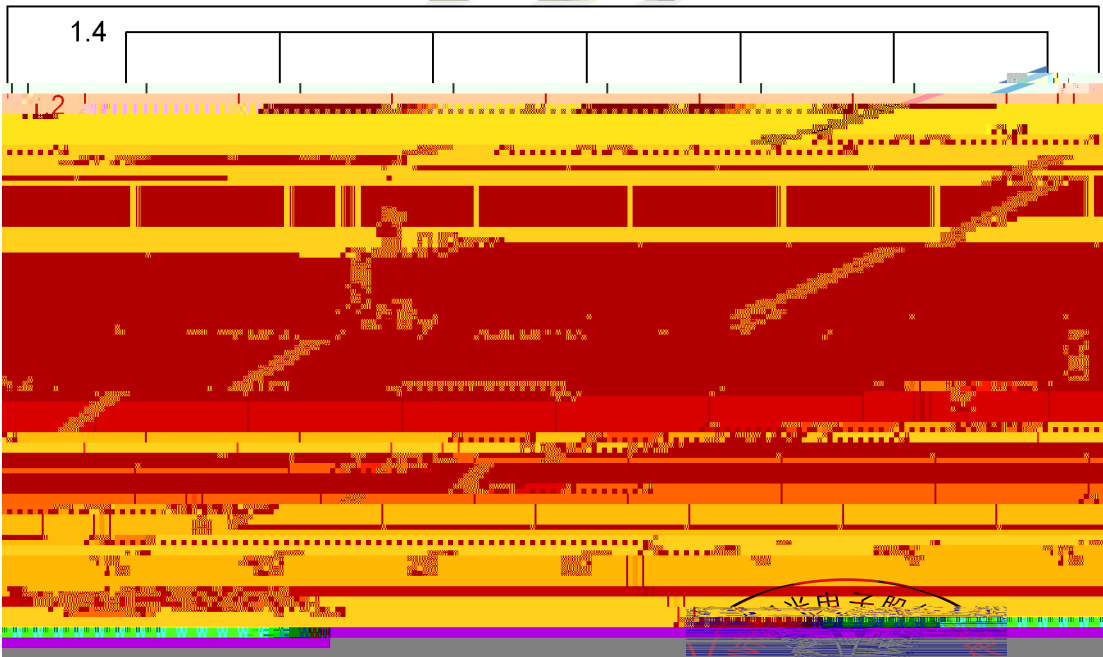
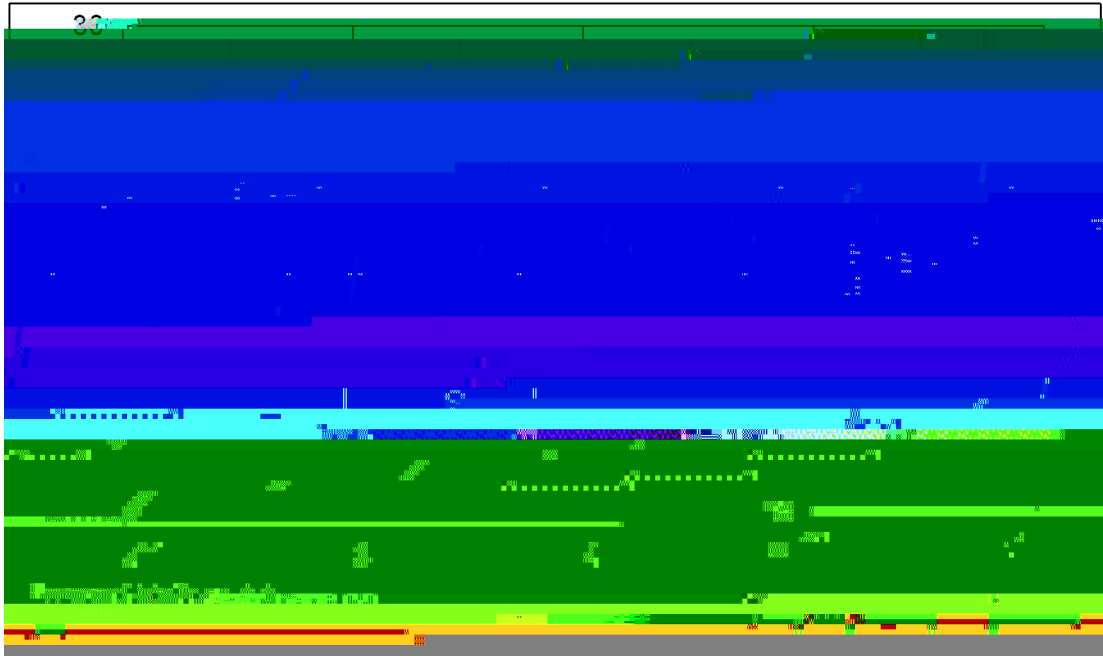

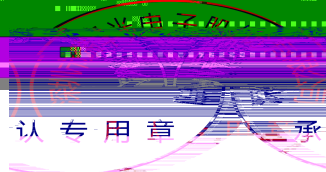
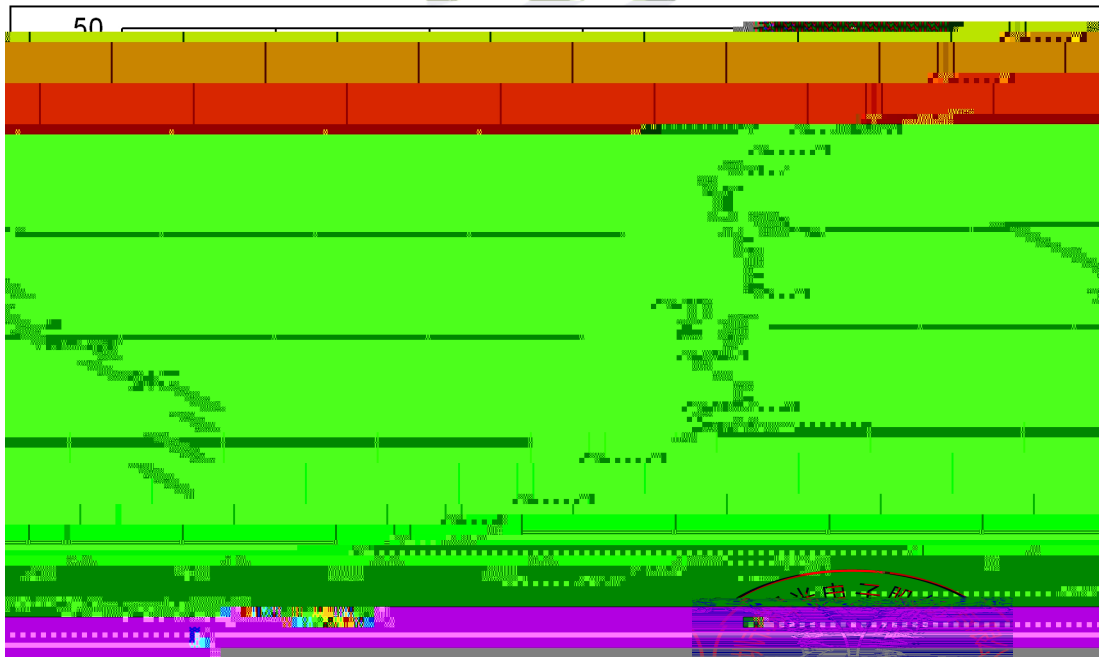
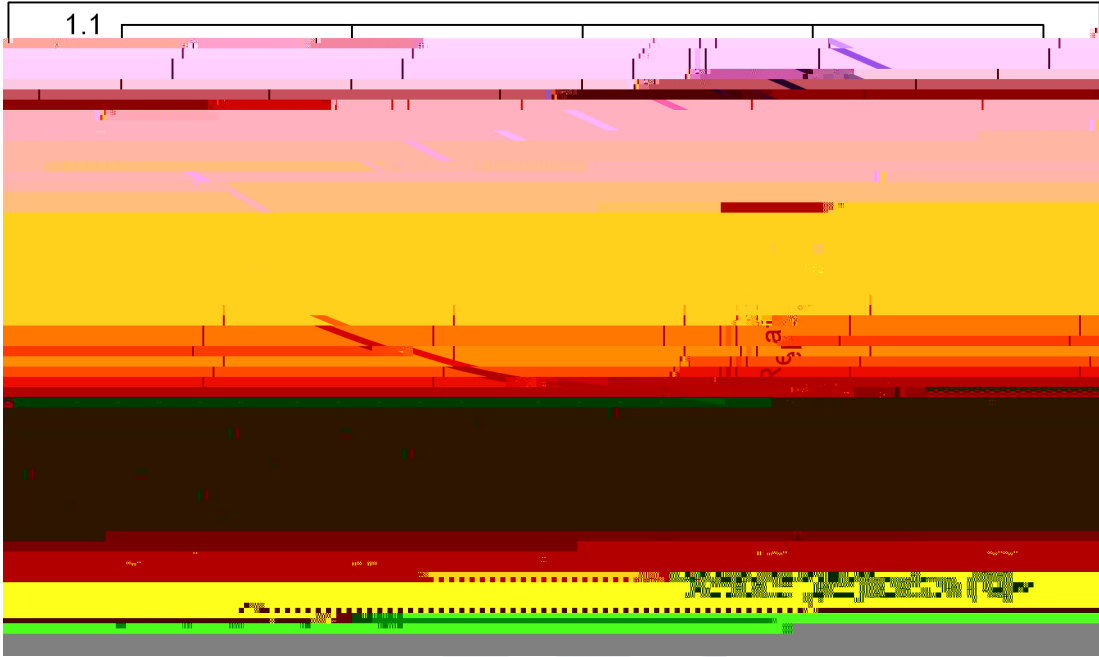

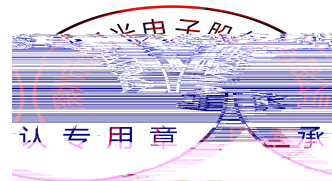
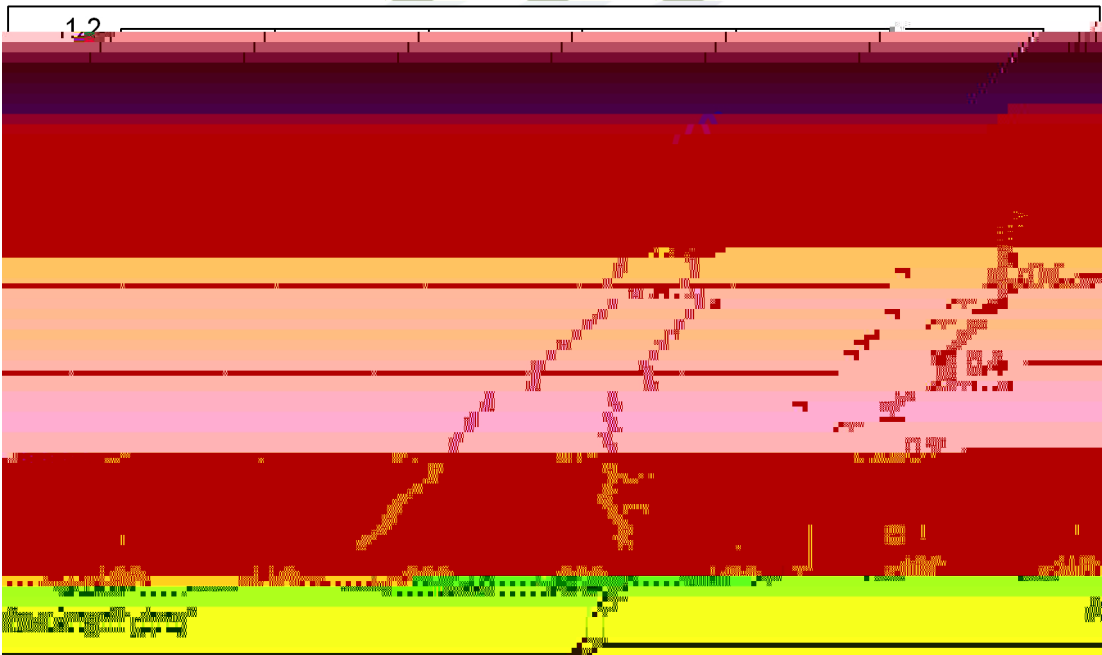
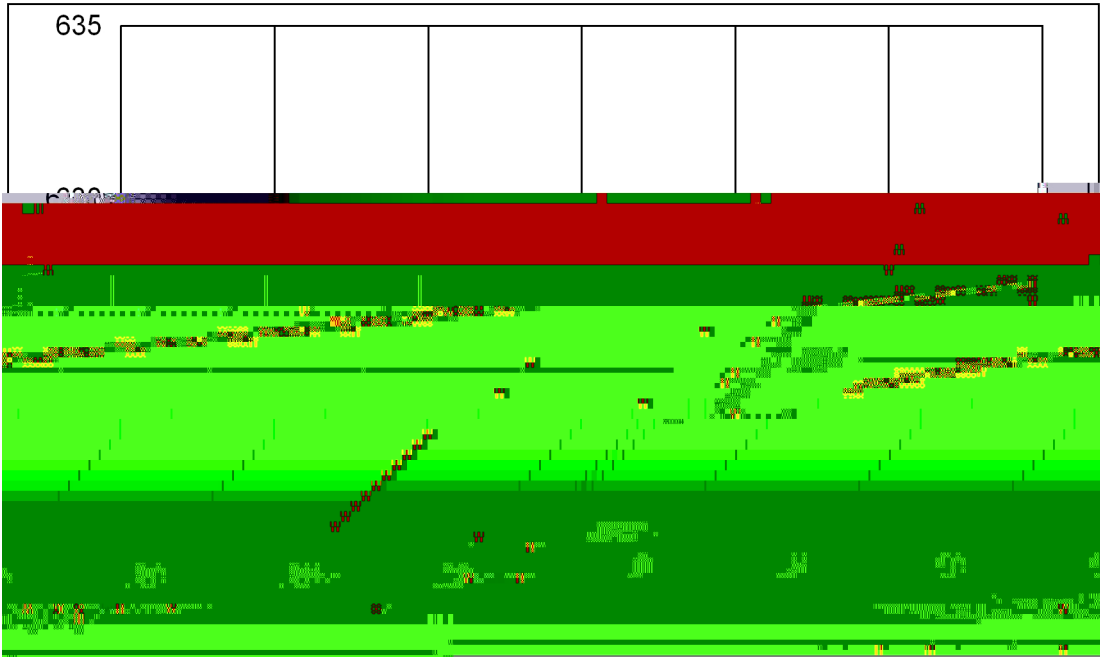

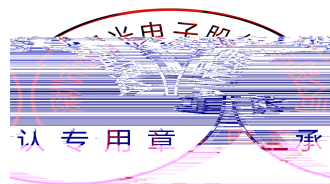
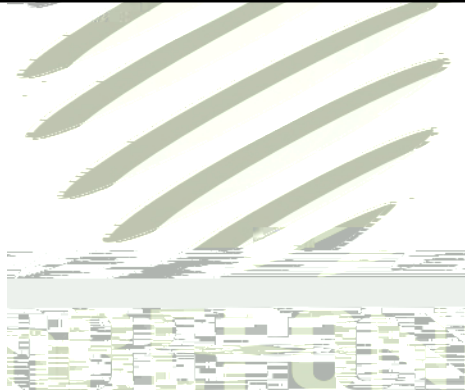
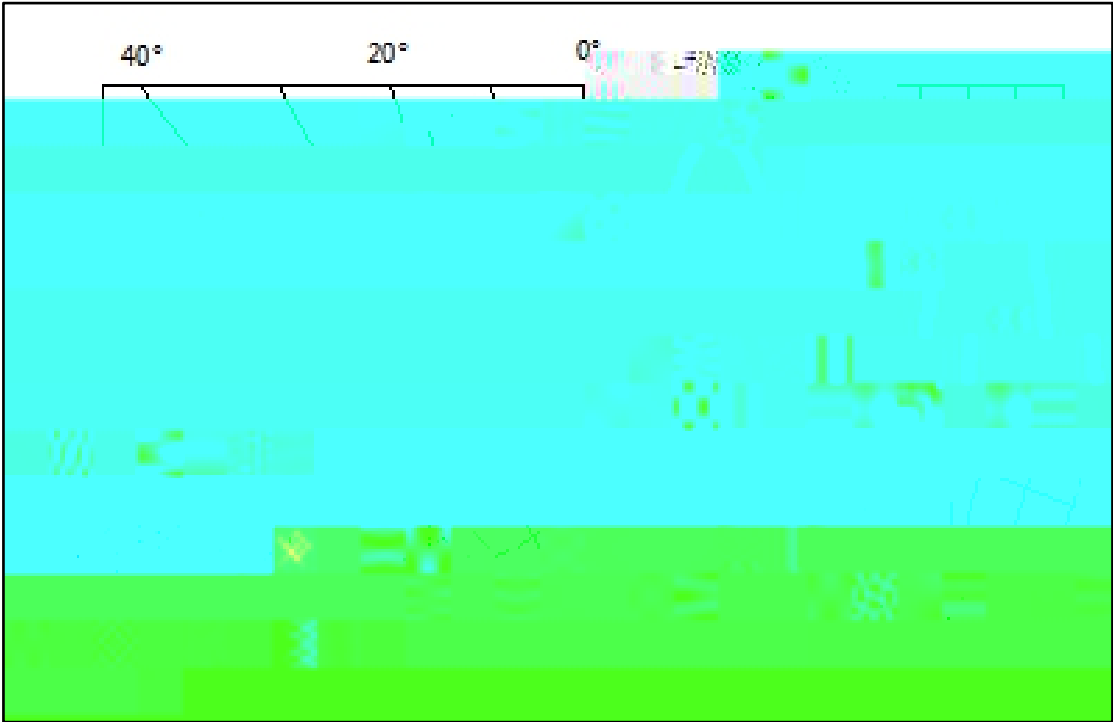

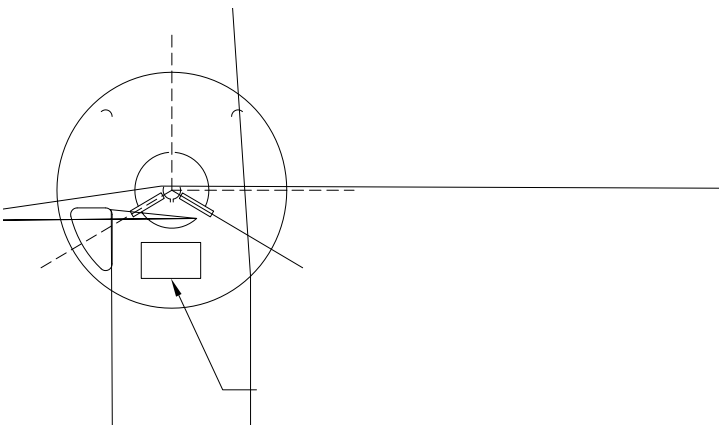
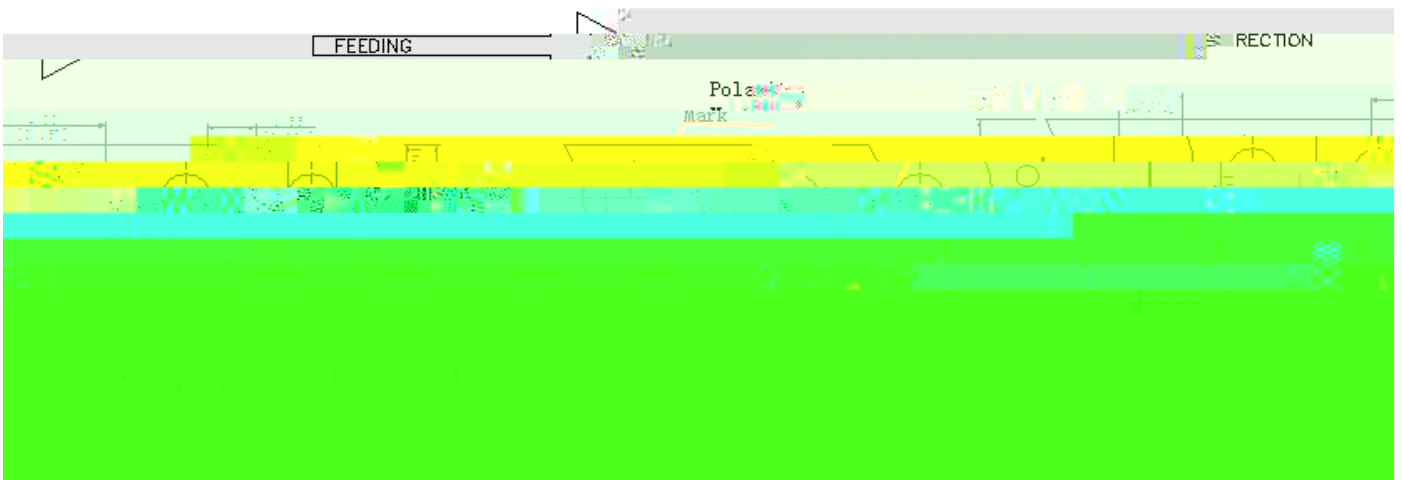



世通云商

REFUND 2017 RECORD 世通云商

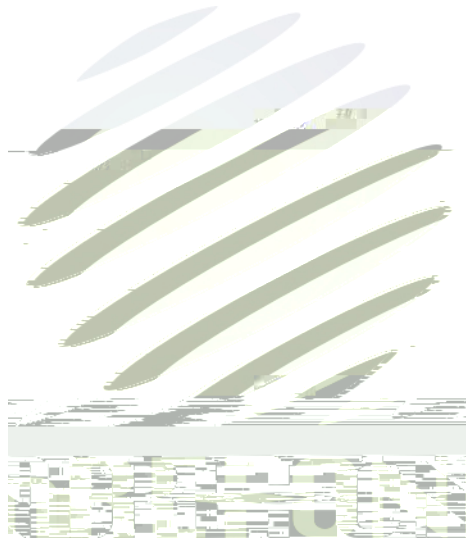

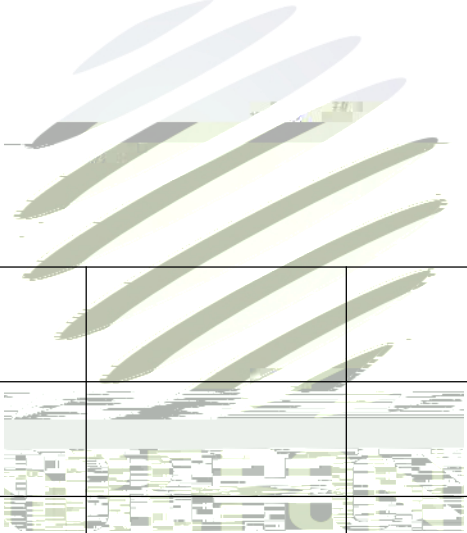
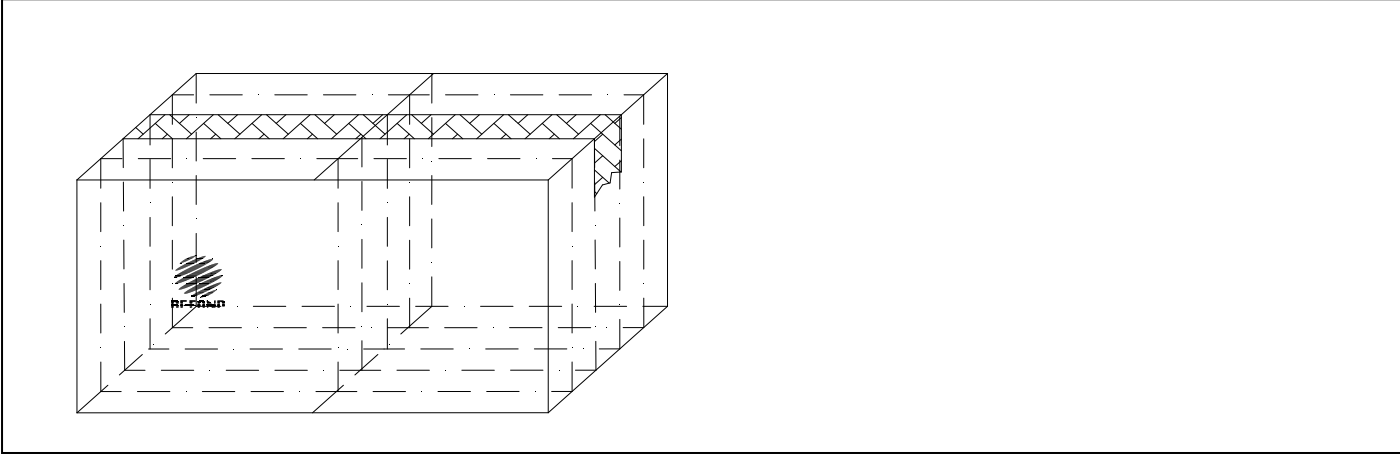



世通电子

REFUND 2017 REFUND 世通电子

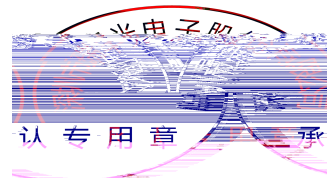
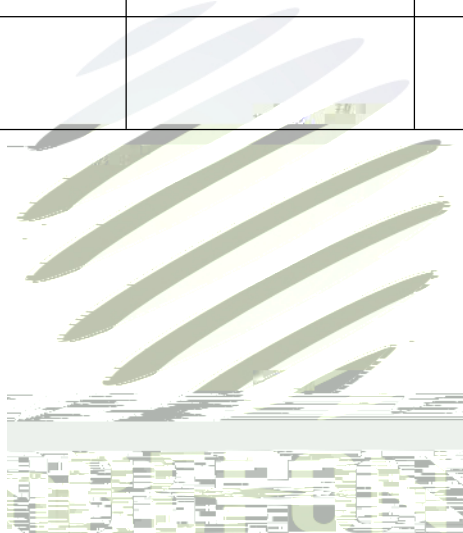

POA

84
FRDDHG

KDLUQJ

GB

WHV

Γ

ABTOI

FS!

KDB·P\B 018(191 09:+

eB

78-D0d!

M

ND

σ

POA

以专用管 承

新科技. 丰富生活!
Innovation. Rich life



世通能源

REFUND 2017 RECORD 世通能源

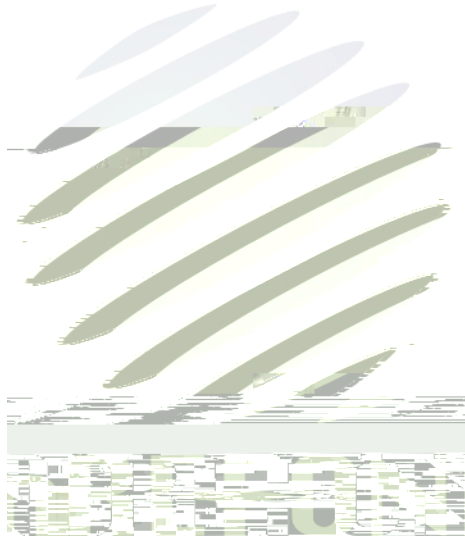
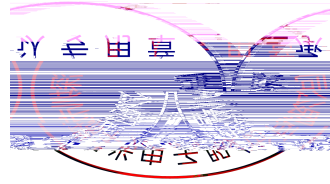

创见

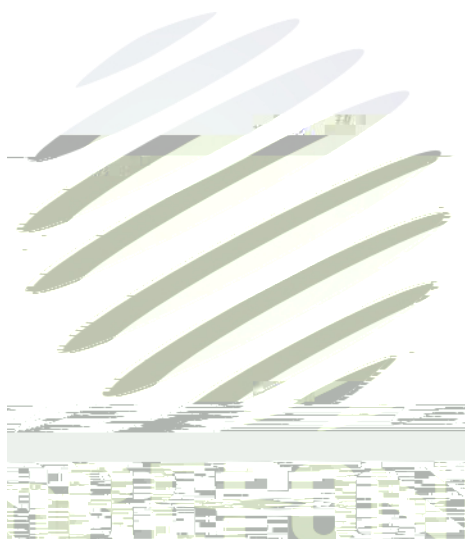



世通电子

REFUND

REFUND

世通电子

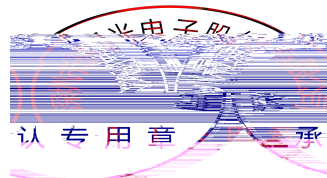
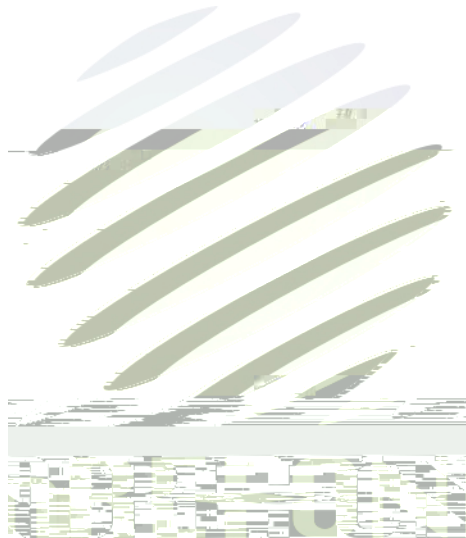



世通电子

SEETUNG ELECTRONIC

